

BARRE PER PRECOMPRESSIONE E POST-TENSIONE - Y1050

Destrosa, laminata a caldo

STRESS BAR - Y1050

Hot rolled, ribbed – right hand thread

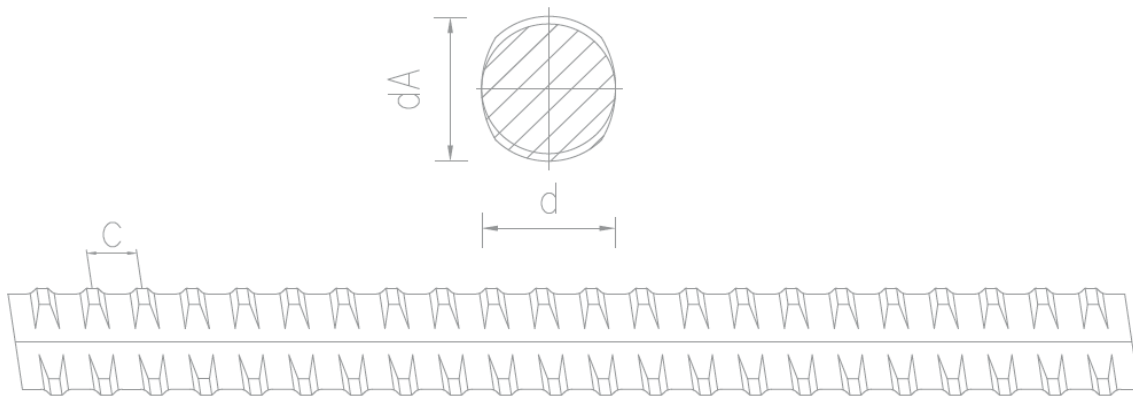

d	mm	18	26,5	32	36	40	47
d_A	mm	21	31	37	42	46	53
c	mm	8	13	16	18	20	21
$f_y/f_{pk}A_{10}^{1)}$	950 N/mm ² / 1050 N/mm ² / 7%						
$F_{y/02}$ (F_{pk})	kN	230	525	760	960	1190	1650
F_{pk}	kN	255	580	850	1070	1320	1820
A	mm ²	241	551	804	1020	1257	1735
G	kg/m	1,96	4,48	6,53	8,27	10,21	14,1

f_{pyk} = tensione di snervamento caratteristica / characteristic yield stress

f_{ptk} = tensione di rottura caratteristica / characteristic break stress

F_{py} = carico di snervamento minimo / minimum yield load

F_{pt} = carico di rottura minimo / minimum break load

A10 = allungamento a rottura su base 10 diametri / extensibility on 10 diameter bases